

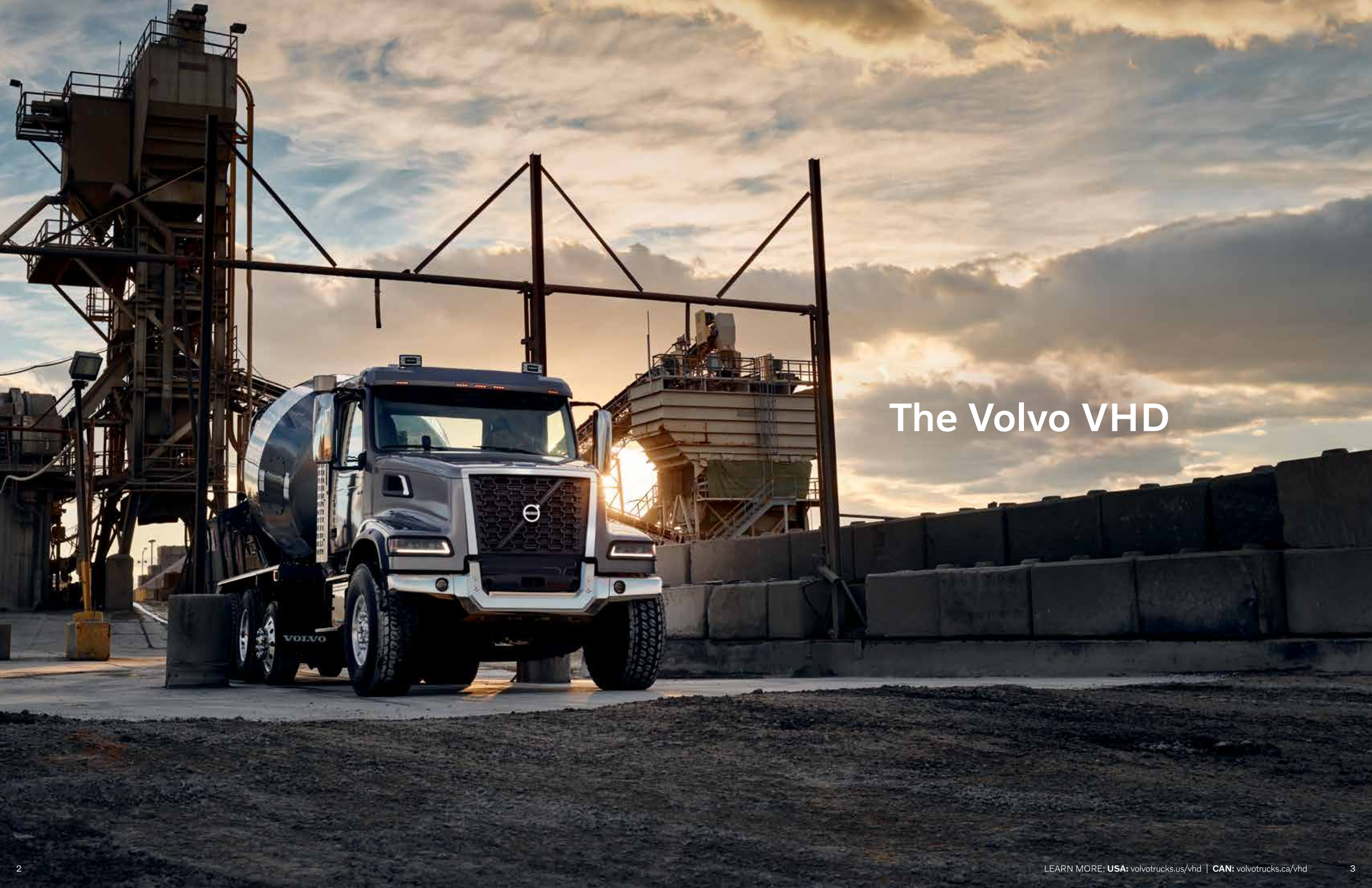

VOLVO **VHD SERIES**

TOUGHER MADE SMARTER





The Volvo VHD



Challenge *accepted.*

You asked for a truck that's incredibly tough, smart, and available with tons of spec options. Our answer was to build the best-looking, most-rugged vocational vehicle in the industry, packed with our most innovative engineering technologies. Your toughest jobs just got easier.

Some great reasons to love the VHD.

Everywhere you look on the VHD, you'll find rugged construction and improvements that will help you tackle your most demanding tasks. From tow hook to taillight, this truck is made to work.

1 **Volvo Active Driver Assist (VADA)**
Next generation VADA technology is now available in the VHD. The system integrates radar and camera technologies, providing constant monitoring of obstacles in front of the truck. This improves safety for drivers.



2 **I-Shift with Crawler Gears**
The crawler option offers one or two additional gears to the innovative I-Shift. The low and ultra-low gears can deliver power and control in demanding situations. I-Shift with Crawler Gears allows the driver to maneuver precisely at speeds as low as 0.6 miles per hour. In addition to low-speed control, it optimizes shifting. Drivers can reach full highway speed at lower RPM's, potentially reducing cycle time and increasing loads delivered daily.

3 **T-Ride suspension**
The VHD suspension system is designed to deliver the best ride even under the most demanding conditions. Our industry-leading suspension articulation can provide constant ground pressure for greater traction. The standard Volvo T-Ride suspension features trunnion-mounted springs and rubber-encased, steel-plated towers for excellent traction and articulation in off-road conditions.



4 **Volvo Dynamic Steering (VDS)**
The revolutionary Dynamic Steering system is now available on the VHD. VDS offers a safer, more comfortable experience operating on the jobsite. It reduces steering strain on the driver at low speed, both in forward and reverse. Over a full day's work this means significantly less strain on arms, shoulders and neck.



5 **Tow pin and bumpers**
The robust VHD bumper features a heavy-duty, 45-mm tow pin rated for a full 80,000 lbs., while the center tow beam is made of 100-ksi steel. The bumper is constructed from 1/4" thick, high-strength alloy aluminum and is supported by welded internal bracing. It features a tough, black powder paint finish, while all steel components are treated for extreme corrosion resistance. A bright trim package is also available.

6 **LED lighting throughout**
The VHD features new LED headlights for greater visibility with distinctive daytime running lights. Turn, marker, and parking lamps are all LED powered. The fully-sealed headlamp component offers a brighter, more focused beam. The new design offers a longer life and even includes an optional heating feature for de-icing in cold weather. The new design offers a longer life and even includes an optional heating feature for de-icing in cold weather.



7 **Latest interior**
All VHD models come with Volvo's acclaimed new interior design. Our well-organized dash and cab come in three different trim levels. To meet the demands of vocational work, the interior is both durable and easy to clean. Seven complementary seat options further increase your choices for customization. The insulated cab, double-sealed doors, and heavy duty floor mats create a quieter work environment.

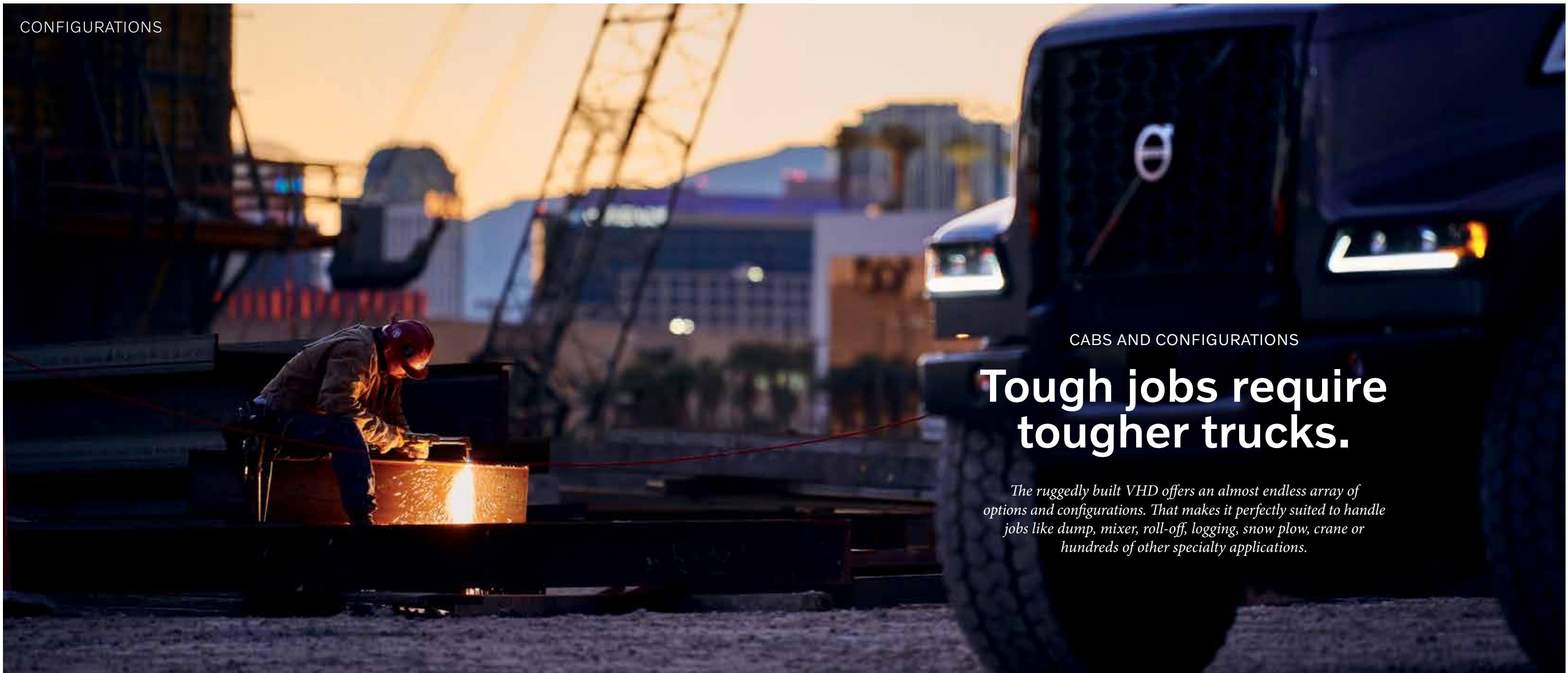

CABS AND CONFIGURATIONS

Tough jobs require tougher trucks.

The ruggedly built VHD offers an almost endless array of options and configurations. That makes it perfectly suited to handle jobs like dump, mixer, roll-off, logging, snow plow, crane or hundreds of other specialty applications.

AXLE BACK CONFIGURATIONS



VHD 300 axle back daycab

VHD 400 axle back sleeper

The VHD's axle back configuration provides one of the industry's tightest turning radiuses, with wheel cuts up to 50 degrees, providing maximum maneuverability. The revolutionary Volvo Dynamic Steering is available in axle back VHD models, to make steering easier and to compensate for the jolts commonly associated with off highway operations.

AXLE FORWARD CONFIGURATIONS



VHD 300 axle forward daycab

VHD 400 axle forward sleeper

The VHD's axle forward configuration provides a longer wheel base, designed to maximize and distribute payload. VHD axle forward models can meet state and provincial axle weight requirements in more regions.



ACTIVE AND PASSIVE SYSTEMS

Volvo is safety.

Volvo stays on the cutting edge of safety technology, ensuring that our trucks are the safest on the road and on the jobsite.

Built to exceed the demanding Swedish Cab Safety Test, our high-strength steel (HSS) cabs have the industry's highest strength-to-weight ratio, protecting the driver by absorbing as much crash energy as possible.

Volvo is the only Class 8 manufacturer to make a driver's side airbag standard equipment in every truck. For added rollover protection, Volvo offers the Rolltek® seat, combining seat belt pre-tensioners, automatic seat lowering to increase survival space, and an integral side airbag that deploys for head and neck protection.

Our new LED headlamps and daytime running lights improve visibility, while wider door openings and ergonomic grab handles make entry and exit safer. Throughout the VHD, Volvo combines advanced engineering with active and passive safety systems, exactly what you'd expect from the inventors of the three-point safety belt.



Volvo Active Driver Assist (VADA)

Our collision-avoidance system integrates radar, camera, and on-board safety features. It can decrease the risk of front or rear-end collisions by 82%. VADA monitors for hazards, from highway speed down to 15 mph, with the ability to completely stop in emergency braking situations. It also provides lane and highway departure warnings.



Volvo Enhanced Stability Technology (VEST)

By continually monitoring operating parameters, VEST detects imminent loss of control, jackknife, or rollover events. The system automatically reduces engine torque and selectively applies braking to help the driver keep the truck on course.



Self-cleaning steps

The VHD features offset steps that are self-cleaning. The built-in grate pattern allows mud, snow or debris to fall through to the ground, providing sure footing. Rigid construction prevents flexing under foot.



Visibility

A one-piece windshield (2,050 square inches) and large side mirrors offer visibility that's among best-in-class for crowded worksites. Flexible dash configuration also allows for addition of exterior cameras, creating 360 views around the vehicle.

Support at every stage.

The VHD is built for body builders. Volvo specialists are available for assistance throughout the process from start to finish.

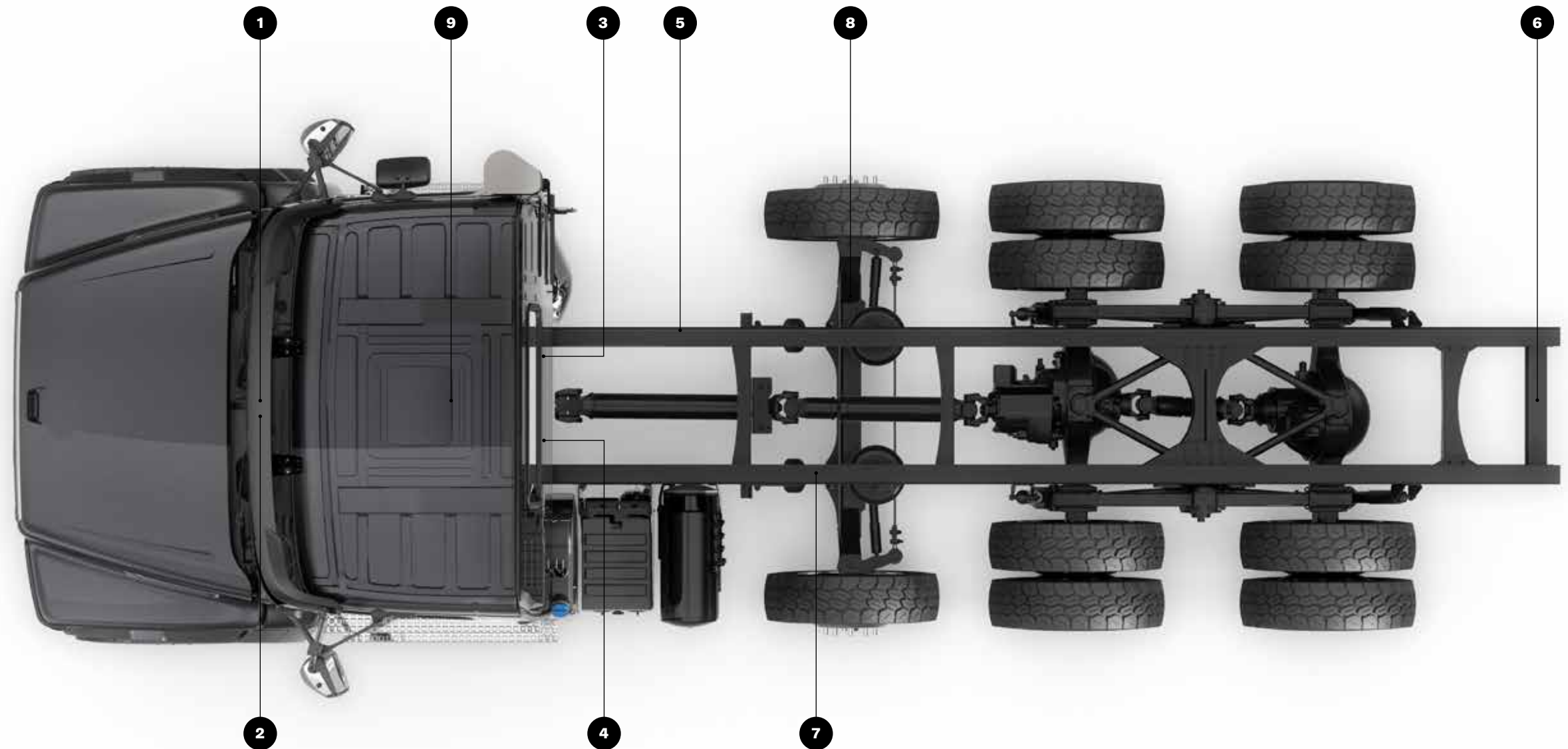

Application specialists

Our dedicated vocational experts will help with your initial specs, so your body builder can start working immediately. After delivery, our body builder specialists are always on call for consultation with your builder.



Online resources

Visit volvotrucks.us/body-builder to find our library of body builder materials. Whether your question is about PTO's or pump speed, you're just a click away from manuals, wiring diagrams, tools, and training.

1. Body control installations

We've created greater space between seats for application-specific controls, such as dump truck, rolloff, and mixers.

2. Body builder module

Makes it easy for the body builder to tap into the truck's electrical system to connect into our flexible dashboard options.

3. Bumper to back of cab (BBC)

The BBC measurement is only 113.6" on the VHD 300 daycab. This leaves plenty of frame rail room for buildout and the ability to customize the rear overhang length.

4. No obstructions

The VHD can be configured to offer a clean back of cab above and below the frame rail. D-shaped fuel tanks allow body builders the most efficient use of space behind the cab.

5. Rigid frame rail

Our high strength, heat-treated steel frame is completely straight and runs parallel behind the cab. The VHD's high-profile frame is available with frame liners and can be custom ordered in four

thicknesses (ranging from $\frac{5}{16}$ " to $\frac{7}{16}$ ") to suit the application and make the body builder's job easier.

6. Crossmembers

Our crossmembers are available in aluminum or steel. The improved crossmember design and positioning reduces weight, enhances frame stability, improves truck handling, and reduces vibration.

7. Corrosion resistance

The frame comes pre-drilled for the builder attachments and is then painted with a heavy-duty urethane coating for extreme corrosion protection.

8. Choices

The more available combinations, the easier a truck is to tailor. That's why the VHD has a long list of options when it comes to axle configurations, chassis heights, and wheelbases.

9. Remote Programming

Software updates and parameter changes to Volvo Powertrain components can be automatically downloaded over the air for maximum productivity.



VOLVO D11 AND D13

Never compromise.

For rough roads and tough loads that are everyday occurrences in vocational applications, we've created two outstanding options that deliver all the power and efficiency you need.

Volvo D11

325-425 hp, 1,250-1,550 lb-ft.

Volvo's family of engines builds on a foundation of proven, mature architecture that leverages innovative hardware to maximize efficiency. The VHD comes standard with the Volvo D11 which is designed with the highest power density ratio we offer. It provides comparable hp and torque to bigger block engines, while weighing 345 pounds less than the Volvo D13. The D11's ratings begin at 325 hp and end at an impressive 425 hp, complete with 1,550 lb-ft. of torque.

Volvo D13

405-500 hp, 1,450-1,850 lb-ft.

When greater horsepower and torque are required for the application, the Volvo D13 is ready to answer the call. Several power ratings are available, topping out at 500 hp and 1,850 lb-ft. of torque. The D13 delivers everything you need to move on or off-road with ease, even on steep grades. Straight torque and multi-torque offerings are available when selecting the D13.

Dynamic duo

The D11 and D13 are designed to pair with our innovative I-Shift for Severe Duty or I-Shift with Crawler Gears (13 or 14 speed). These rugged automated manual transmissions feature upgraded engaging sleeves, clutch durability, and torsional dampening to withstand the rigors of heavy payloads. Volvo engines paired with an I-Shift keep fuel costs down, slow driveline wear, reduce noise, extend powertrain life, and lower maintenance costs.

Power take-off

The VHD has you covered when it comes to PTO configurations. Drive connections are available in three positions (front engine PTO, rear engine PTO, and transmission-mounted PTO) for gear pumps, piston pumps, or direct drive shaft connections. PTO's on the Volvo powertrain provide superior reliability because the pumps are direct coupled during factory installation.

Powerful and precise engine braking

Service brakes can take a beating on jobsites. The intelligent Volvo Engine Brake (VEB) is an enhanced system that gives drivers precise control over engine braking and saves the truck's service brakes for when they're needed most. It can provide phenomenal retarding horsepower even at low engine rpm and vehicle speeds, allowing drivers to walk the vehicle downhill without a foot on the brake pedal. The VEB will extend brake life and reduce maintenance costs for your VHD.



I-SHIFT FOR SEVERE DUTY

There's nothing it can't handle.

I-Shift for Severe Duty seamlessly integrates with the D11 and D13 to ensure shifts are smooth and at the ideal engine speed. It saves wear and tear to extend drivetrain life.

Every VHD comes standard with a Volvo Power D11 engine and I-Shift for Severe Duty transmission. This I-Shift is designed for on- and off-road work in applications that require frequent shifting. It includes upgraded hardware and software, improved engaging sleeves for greater durability, and a new countershaft brake for improved performance and smoother shifting.

With I-Shift you get the industry's highest gear ratio over the first five gears, providing greater torque at the start, when you need it most. Choose the Performance Plus software package and you can select between manual, economy, and performance drive modes that maximize power and gradability when needed.

The I-Shift can be factory ordered with a variety of power take-offs. When you order your VHD with a PTO on the I-Shift, the truck comes standard with a wiring prep kit, including a 6 o'clock 4-bolt provision opening.



I-SHIFT WITH CRAWLER GEARS

The low-speed solution for high-pressure projects.

When steep-grade startability and low-speed maneuverability are critical, I-Shift with Crawler Gears is the answer on the jobsite.

The crawler option can add one or two gears to a 12-speed I-Shift. Low (13th gear) and ultra-low (14th gear) both provide low-speed control for maximum Gross Combined Weight (GCW) loads. The transmission's upgraded software optimizes shifting for higher weight applications, allowing shifting to occur at higher rpms, and enabling drivers to control downshifts.



Curb pour

The I-Shift with Crawler Gears' weight capacity is among the industry's highest for automated manual transmissions. It enables controlled forward and reverse travel at extremely slow speeds, down to 0.6 miles per hour, perfect for paving and curbing applications.



Make the grade

No two jobsites are the same. I-Shift with Crawler Gears allows the VHD to handle almost any incline, even from a standstill. That's made possible by a 32:1 forward gear ratio and 37:1 ratio for reverse. These ratios for the ultra-low gear can significantly reduce wear on the clutch.



INNOVATIVE TECHNOLOGY

Faster cycle times. Larger profits.

*Our innovative design means your loads move faster on highway.
Cycle times go down, enabling drivers to move more loads per day.*

Moving rapidly to and from the jobsite can be crucial to your bottom line. Volvo's powertrain innovations allow you to reach highway speeds at lower RPM's. The VHD features 13 and 14 gear I-Shift options which generate low-end torque for startability, while still providing ultra-efficient operation on highway.

Lower highway RPM's also mean less fuel consumption. So operating costs can go down, even as payloads go up.

Upgradeability

The clutch and transmission can handle any of the ratings inside an engine family. So power and torque settings can be upgraded with no change in hardware. A simple software update is all that's required.

Performance Plus mode

I-Shift's transmission electronics offers a Performance Plus mode specifically designed for vocational applications. The mode adapts gearshifts and selections to poor driving surfaces and hilly paths. Power Launch, Rock Free, and Paver Assist are all settings within Performance Plus mode.

Power Launch allows the truck to free itself when stuck with a burst of torque. It minimizes wheel-slip on soft surfaces and improves startability when fully loaded.

Rock Free creates a smooth rocking motion to free the vehicle. Often used when starting from a standstill on uneven surfaces, Rock Free provides a gentler way to get the vehicle moving that may be important with some payloads.

Paver Assist is a special I-Shift feature that lets drivers engage drive without first applying the brakes when transitioning from neutral to operation. This minimizes disturbances while being pushed by a paver, eliminating variances in asphalt distribution during paving.





T-RIDE SUSPENSION

Tame the terrain.

The VHD suspension system is designed to deliver the best ride even under the worst conditions.

Our industry-leading articulation can provide constant ground pressure for greater traction. The standard Volvo T-Ride suspension features trunnion-mounted springs and rubber towers for excellent traction, roll stability, and articulation in off-road conditions.

With rear axle capacities to 58,000 pounds, a full 17 inches of cross-articulation on each individual wheel end, low-maintenance nylon bushings, and maintenance-free sealed V-rods and torque rods, Volvo's T-Ride suspension delivers non-stop performance in extreme conditions. All with little to no maintenance.

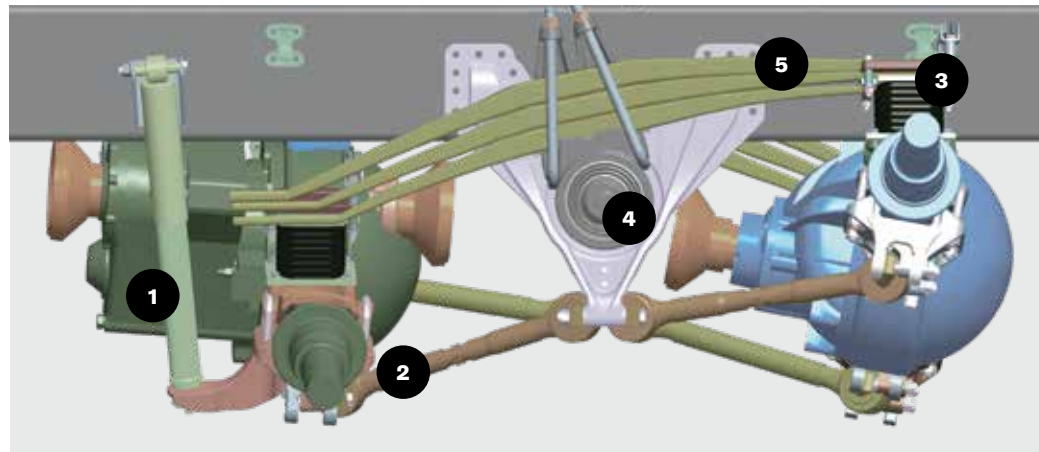

1. SHOCK ABSORBERS

Two or four shock absorbers dampen force evenly.

2. ALIGNMENT ARMS

Four maintenance-free alignment arms maintain axle geometry without limiting movement.

3. TOWER

Rubber-encased, steel-plated tower provides only vertical loading to springs.

4. BUSHING

Maintenance-free rubber bushing improves uptime.

5. WEIGHT CAPACITY

T-ride suspension offers weight rating options from 40,000 to 58,000 pounds.

Four parabolic spring types are offered:

- 5-leaf soft
- 3-leaf
- 3-leaf extra firm
- 2-leaf firm

We also offer an 11-leaf Multi-Leaf Suspension.

V-RODS (not pictured).

Twin v-rods offer superior bushing life and maintain axle geometry without limiting movement.



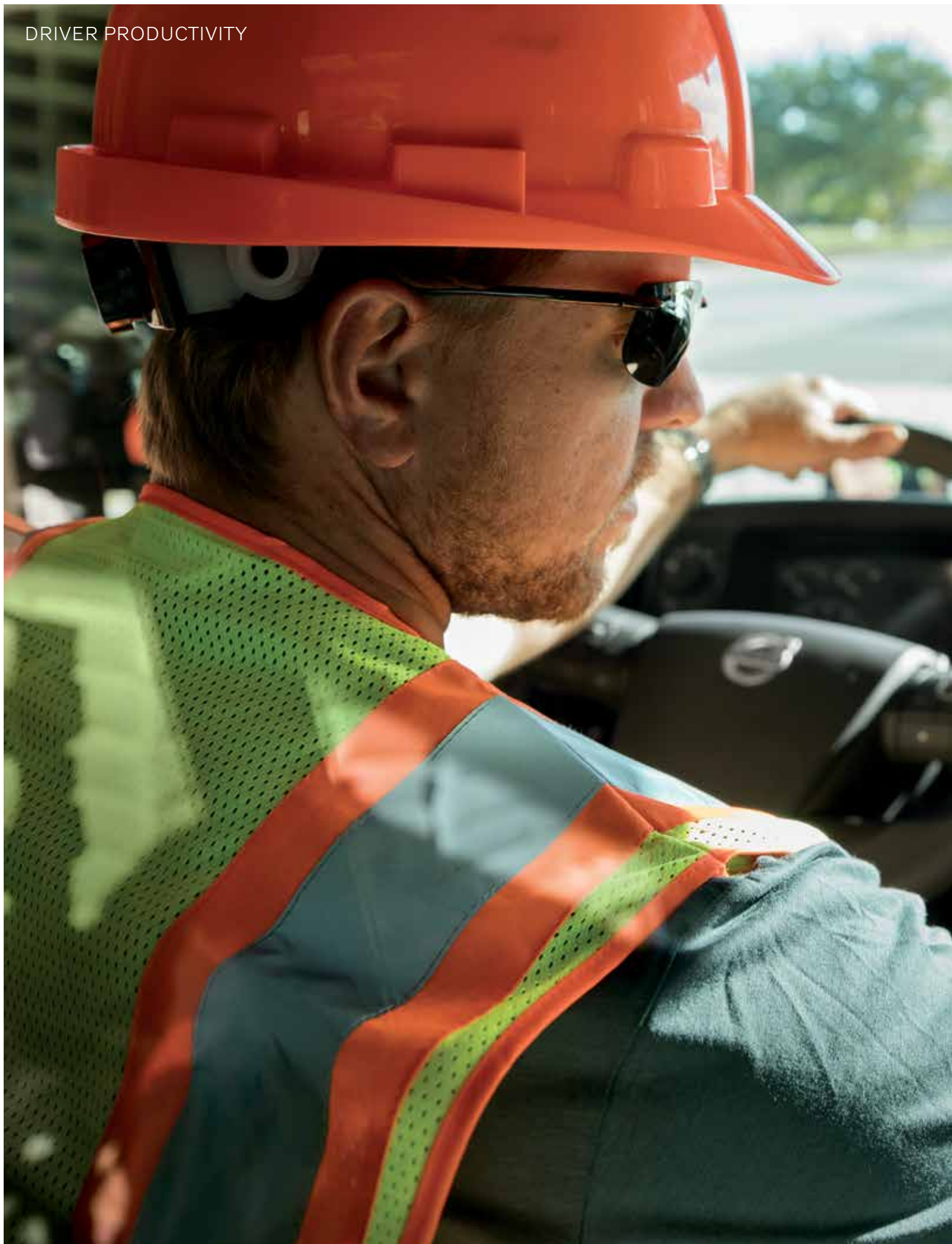

CAB INTERIOR

It's not just workspace, it's a space that works.

The VHD features Volvo's most innovative cab design, improving comfort and productivity.

We worked hard to understand driver productivity better than anyone. Then we turned that knowledge into profits for you, by surrounding your driver with a premium work environment.

Our ergonomic seat design and dashboard layout put the driver comfortably in command. Position Perfect™ steering provides three-way neck tilt, giving drivers the ability to place the steering wheel exactly where they want it.

Thoughtful touches can be found throughout the cab. Surfaces throughout the interior are designed for easy cleaning. While durable kick panels and removable floor mats are ready to handle the constant entry and exit of vocational work.

There's even a dash-top tray with multiple USB and 12V connections to provide a safe, convenient home for a driver's many gadgets. And those devices can also be linked to the optional in-dash infotainment system.



Configurable Driver Information Display

At the heart of the new and improved instrument cluster is a color LCD display. A full five inches wide, it can be configured to provide trip information, performance data, and a wide range of vehicle diagnostics.



Additional control cluster

Volvo integrates a wide selection of standard switches and gauges in every VHD. But because each application is unique, we've conveniently allocated space on the dash for you to customize additional gauges for your specific loads.



Quiet interior

Double-sealed doors and an insulated cab reduce noise inside the vehicle. It's crucial to drivers in loud worksites, and with applications like mixers where PTO's are constantly adding to the noise levels around the truck.



Close at hand

Multiple systems can be controlled through steering wheel-mounted switches. The touch-friendly switch layout enables cruise control, entertainment, and other settings to be changed from the wheel.

SLEEPERS

To improve your sleep, we improved our sleeper.

Volvo VHD sleepers offer premium touches that give drivers a comfortable place to relax and recharge when regional hauls require an overnight stop. With a 36-inch wide bed, the 42-inch flat-roof VHD 400 sleeper provides ample room to rest.

A thick layer of insulation keeps the cab comfortable and quiet whether you're down for an hour or for the night.



Don't get up

The sleeper control panel can be used to lock the doors, adjust bunk heating and cooling, or set audio levels. Need assistance? Just press the "panic" button to call attention to your vehicle.



Snacks and refreshments

The VHD comes with the option of a refrigerated drawer under the passenger seat. Perfect for storing drinks or snacks.

VOLVO DYNAMIC STEERING

Revolutionary control.

Our revolutionary Dynamic Steering system is now available for the VHD.

Volvo Dynamic Steering (VDS) creates a safer, more comfortable experience for drivers. Available in all axle back VHD models, VDS can eliminate many of the steering jolts that drivers usually absorb in their arms and shoulders when moving over rough terrain. The expected torque from bumps and potholes is compensated for before it reaches the driver. It can also reduce steering strain when traveling at low speeds, both in forward and reverse.

The system features a powerful electric motor mounted above the hydraulic steering gear to provide additional torque when necessary. It receives input 2000 times per second from sensors throughout the truck monitoring yaw rate, steering angle, wheel speed, and the driver's own actions. Optimal steering input is constantly calculated based on conditions to assist with rough terrain, highway crowning, soft shoulders, crosswinds, and even emergency situations like blowouts.



Fewer aches and pains

VDS dampens the vibrations commonly found in off-highway applications. It constantly makes small adjustments, so the kicks from bumpy dirt roads can disappear. Course corrections from braking on uneven surfaces are virtually eliminated as well. Over a full day's drive, this means significantly less strain on the driver's arms, shoulders, and neck.



Low-speed maneuverability

Dynamic Steering provides two big advantages when turning at low speeds and reversing in tight spaces. Additional steering torque automatically feeds into the system, allowing the driver to maneuver with a light touch. The steering wheel will return to center when needed, saving driving effort and bringing the vehicle into a straight line quickly and easily.



Compensating in crosswinds

Aftermarket bodies, like mixer barrels, can be particularly hard on drivers during windy conditions. The VDS system can greatly reduce the constant need for steering corrections during crosswinds. It helps the driver stay on a straight course through small, precise directional adjustments.



PRODUCTS AND SERVICES

We're with you every minute, every day.

Remote Diagnostics connects your vehicles to you, your dealer, and the Volvo Uptime Center 24/7.

Standard in every Volvo-powered VHD, Remote Diagnostics can help avoid unexpected downtime with constant monitoring of your Volvo engine, I-Shift, and aftertreatment. It offers a range of unique benefits, including enhanced proactive diagnostics, detailed analysis of critical fault codes for repair planning, immediate communication if actions are required, and streamlined service procedures.

With a dedicated team of professionals available around the clock at Volvo's world-class Uptime Center in Greensboro, NC, Volvo goes beyond diagnostic technology to deliver actionable solutions. It's a powerful service that reduces average diagnostic times by 70% and average repair times by 22%.



Volvo Uptime Center

Real people. Real solutions. Real fast. The Volvo Uptime Center offers around-the-clock assistance anywhere in the United States and Canada. Within minutes, your driver is connected to a member of Volvo Action Service, a team of highly trained uptime experts who can quickly manage service, schedule repairs, and tackle any other issue that happens on the road.

Body builder support

There is a trained group of vocational truck specialists always on call inside the Volvo Uptime Center. These experts are dedicated to assisting body builders with aftermarket support once the truck is delivered for body construction. They can answer technical questions that arise during the build and guide your body builder through our online builder portal.



Premium Maintenance Plan

For best results, plan ahead. Preventive maintenance plans improve vehicle uptime, increase productivity, and provide peace of mind by making sure all required maintenance is done efficiently and done right. Choose from a full menu of services and get access to Genuine Volvo Parts, warranty adjustments, service programs, and performance updates at pre-planned maintenance intervals.



Updates on the fly

Volvo's new Remote Programming feature means you'll no longer have to take your vehicle out of service to perform certain software and parameter updates like transmission performance mode, engine idle shutdown, and weight-based road speed limits. The driver receives notifications that update or parameter changes are available. The software download can then be done at their convenience, using the in-dash Driver Information Display.



DEALER NETWORK

Always where you need us most.

Our world-class dealer network means your trucks are never far from the quality care and maintenance you expect when you buy a Volvo truck.

On a jobsite, time means money. Our Uptime Services are here to save you both. With more than 400 dealers and thousands of service locations across North America, Volvo Trucks Uptime Services help you through every step of a service event and make sure your trucks stay where they belong—on the job.

Because the VHD has our most advanced telematics package, the dealership has complete access to the truck's engine data, diagnostic codes, and the current status of crucial components. We can prepare to address issues before your vehicle arrives at the dealership or even help predict unplanned stops and offer solutions.

When maintenance work or repairs are needed, they'll be done fast and accurately by highly trained Volvo specialists. Every Volvo dealer is backed by our parts-expediting team which locates the parts you need. It assures that your vehicle is back to work quickly.

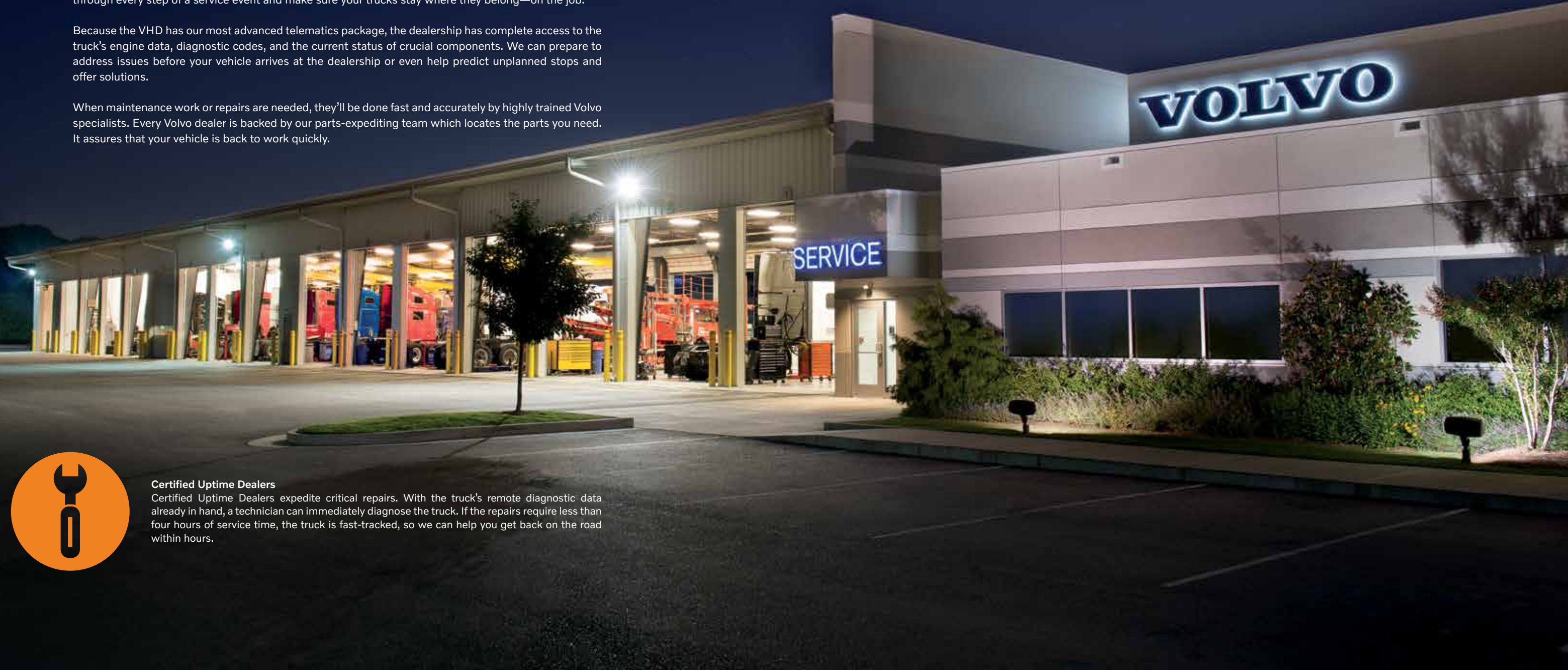

Certified Uptime Dealers

Certified Uptime Dealers expedite critical repairs. With the truck's remote diagnostic data already in hand, a technician can immediately diagnose the truck. If the repairs require less than four hours of service time, the truck is fast-tracked, so we can help you get back on the road within hours.

Choose your Volvo VHD.

This is just a hint of all the choices you have when tailoring your Volvo VHD to your needs. The full specifications and all possible options are available at your local Volvo dealer or at volvotrucks.us



**VHD 300F
axle forward**

**VHD 300B
axle back**

**VHD 400F
axle forward**

**VHD 400B
axle back**

Description	Daycab designed for applications requiring a bridge-law compliant wheelbase.	This daycab provides maximum maneuverability on the jobsite.	Flat-roof sleeper designed for vocational applications requiring overnight rest periods and a bridge-law compliant wheelbase.	Flat-roof sleeper designed for vocational applications requiring overnight rest periods and maximum maneuverability.
Vehicle Configuration	Straight truck or tractor			
Cab Type	Daycab		42" Sleeper	
Interior Height	61"		61.5"	
Interior Width	83.5" door to door		83.5" door to door with 75"x 36" mattress	
BBC	113.6"		145.6"	
Drive Axle Configuration	Single, tandem, tri-drive			
Frame Length	Up to 480"			
Rear Axle Ratings	23K-69K			
Lift Axle	Tag and pusher, up to 2 factory installed			
Rear Suspension	Multi-leaf Spring T-Ride Primaax HAS Haulmaax			
PTO	Rear engine mounted, front engine mounted, transmission mounted			

For more details and availability of other custom options contact your local Volvo dealer.



Volvo D11



Volvo D13

Engine:		
HP/Torque ratings	325-425 hp / 1,250-1,550 lb-ft.	405-500 hp/1,450-1,850 lb-ft.
Base Engine Configuration	4 cycle / Inline Six	
Emissions	SCR Selective Catalytic Reduction	
Aspiration	Sliding Nozzle Variable Geometry Turbocharger	
Cam / Valve Configuration	SOHC / 4 Valves per Cylinder	
Cylinder Head	One Piece Rigid Deck	
Injection System	Common-Rail	
Maximum Fuel Injection Pressure, psi (bar)	35,000 (2,400)	
Upgrade	Software Only, Throughout Range	
Displacement, cu. in. (L)	661 (10.8)	780 (12.8)
Compression Ratio	17:1	
Bore & Stroke, in. (mm)	4.84 x 5.98 (123 x 152)	5.16 x 6.22 (131 x 158)
Full Dress Dry Weight, lb. (kg)	2,259 (1,025)	2,605 (1,182)
Fuel and Lubrication:		
Fuel Specification	Ultra Low Sulfur Diesel, 15 ppm	
Fuel Filters	Primary plus Secondary	
Total Lube Oil Capacity, qts. (L)	38 (36)	42 (40)
Oil Filtration	Two Full Flow, One Bypass	Two Full Flow
Oil Drain Interval, Normal Service, miles (km)	60,000 (96,561)*	
Oil Specification	Volvo VDS-4.5, SAE 10W-30	
FLOCS Oil Drain Kit	Optional	
Ancillary Equipment:		
Air Compressor, CFM	Two Cylinder, 31.8	
Engine Brake	Volvo Engine Brake (VEB)	
Engine Brake Rating at 2,200 rpm	420 hp @ 2,200 rpm	500 hp @ 2,200 rpm
Engine Brake Rating at 1,500 rpm	266 hp @ 1,500 rpm	350 hp @ 1,500 rpm
PTO Port for Live Rear PTO Pump or Shaft	Optional	
Preheater, Electrical	Optional	

* Volvo-branded VDS4.5 oil and > 6 mpg.



Volvo I-Shift for Severe Duty

Volvo I-Shift with Crawler Gears

Allison 3000 RDS Series

Allison 4000 RDS Series

Allison 4500 RDS Series

	Direct	Overdrive	Overdrive	Overdrive
Max Torque Capacity (lb-ft.)	1,900	1,900	1,900	1,900
Overall Gear Ratio	14.94	15.04	22.35	41.08
Forward Gears	12	12	13	14
Reverse Gears	2 to 4	2 to 4	3 to 6	3 to 6
Dry Weight with Clutch and Oil Cooler (lbs.)	720	720	805	809
Max Haul Weight (1k lbs.)	143	143	220*	220*
Transmission Body Housing	Aluminum	Aluminum	Aluminum	Aluminum
Transmission Warranty — Heavy Duty	3 yrs/ 250k miles	3 yrs/ 250k miles	3 yrs/ 250k miles	3 yrs/ 250k miles
Clutch Warranty — Heavy Duty	3 yrs/ 250k miles	3 yrs/ 250k miles	3 yrs/ 250k miles	3 yrs/ 250k miles
Oil Drain Interval	3 yrs/ 250k miles	3 yrs/ 250k miles	3 yrs/ 250k miles	3 yrs/ 250k miles
Oil Volume (quarts)	16.2	16.2	17.9	17.9
Monitored by Remote Diagnostics	✓	✓	✓	✓
Remote Programming OTA	✓	✓	✓	✓
Hill Start Assist	✓	✓	✓	✓
Ability to Upgrade Engine Torque	✓	✓	✓	✓
Ability to Rock Free	✓	✓	✓	✓
Power Launch	✓	✓	✓	✓
Kick Down	✓	✓	✓	✓
Grade Sensor	✓	✓	✓	✓
Performance Software	✓	✓	✓	✓
Manual Mode	✓	✓	✓	✓
Ability to Lock in a Gear	✓	✓	✓	✓

* Capable of up to 220k GCW that includes Heavy Duty and Severe Duty Transmission Warranty.

	Automatic	Automatic	Automatic
Max Torque Capacity (lb-ft.)	1,250	1,850	1,850
Overall Gear Ratio (span)	9.5	10.42	13.33
Forward Gears	6		
Reverse Gears	1		
Dry Weight with Clutch and Oil Cooler (lbs.)	625	943	943
Max Haul Weight (1k lbs.)	80k	Unlimited**	Unlimited**
Transmission Body Housing	Aluminum		
Transmission Warranty — Heavy Duty	3 yrs		
Clutch Warranty — Heavy Duty	N/A		
Oil Drain Interval	Prognostics		
Oil Volume (quarts)	32	53.2	53.2
Monitored by Remote Diagnostics	×	×	×
Remote Programming OTA	×	×	×
Hill Start Assist	✓ ***	✓ ***	✓ ***
Ability to Upgrade Engine Torque	×	×	×
Ability to Rock Free	✓	✓	✓
Power Launch	✓ ***	✓ ***	✓ ***
Kick Down	×	×	×
Grade Sensor	✓	✓	✓
Performance Software	✓	✓	✓
Manual Mode	✓ (limited)	✓ (limited)	✓ (limited)
Ability to Lock in a Gear	×	×	×

** If certain conditions are met.

*** With torque converter.



GABRIELLI TRUCK SALES

gabriellitruck.com

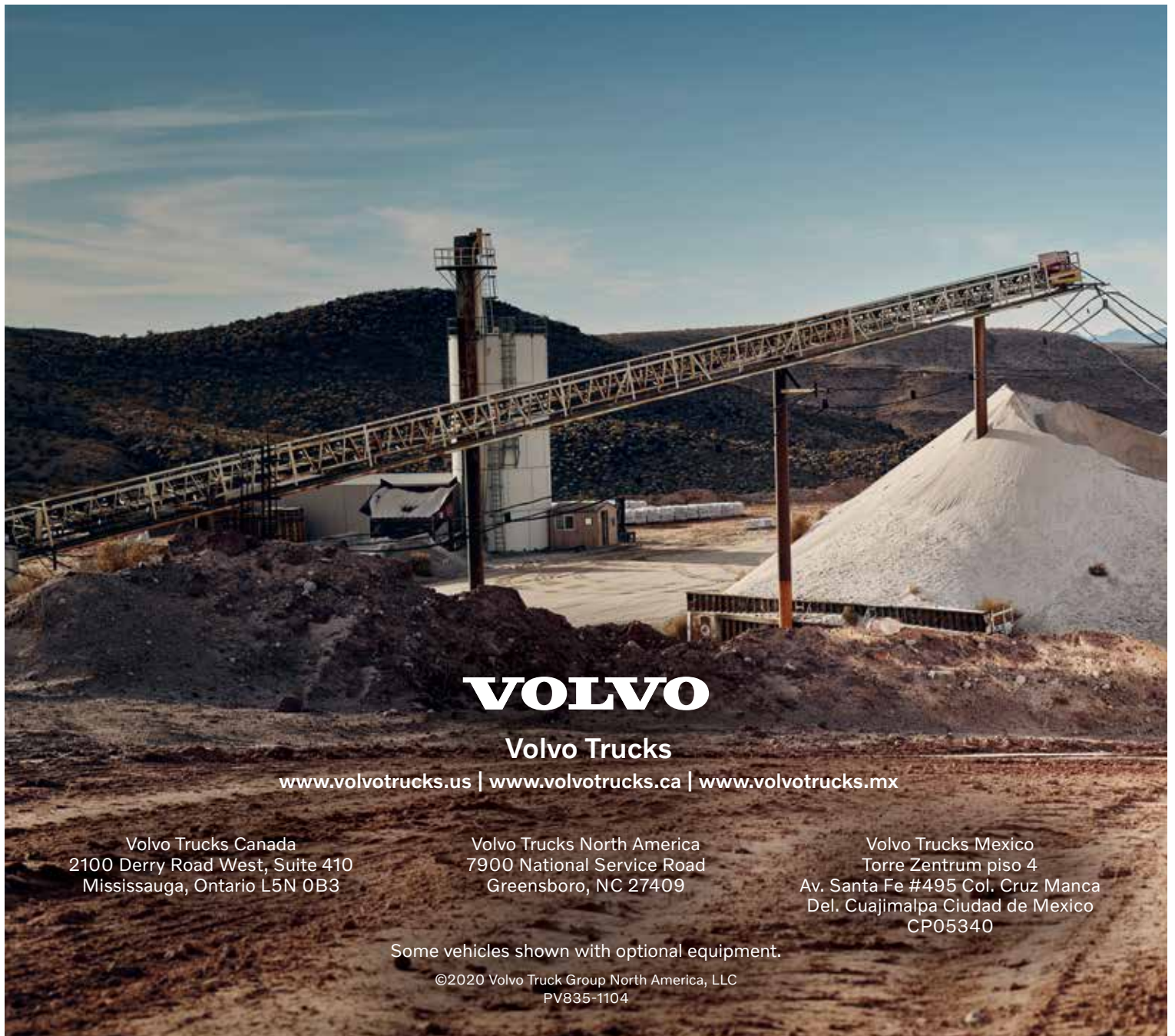

VOLVO

Volvo Trucks

www.volvotrucks.us | www.volvotrucks.ca | www.volvotrucks.mx

Volvo Trucks Canada
2100 Derry Road West, Suite 410
Mississauga, Ontario L5N 0B3

Volvo Trucks North America
7900 National Service Road
Greensboro, NC 27409

Volvo Trucks Mexico
Torre Zentrum piso 4
Av. Santa Fe #495 Col. Cruz Manca
Del. Cuajimalpa Ciudad de Mexico
CP05340

Some vehicles shown with optional equipment.

©2020 Volvo Truck Group North America, LLC
PV835-1104