



**GABRIELLI
TRUCK SALES**



**FARMERS
MARKET**

VIEWPOINT
PUBLIC SEATING
LOWER
MARKET
LEVELS

K270/K370



**KENWORTH.
The World's Best.**



 **KENWORTH.**
The World's Best.



K270/K370



VERSATILE

PRODUCTIVE

EFFICIENT

AGILE, VERSATILE, RELIABLE AND EFFICIENT, THIS IS YOUR UPTOWN SOLUTION TO DOWNTOWN DELIVERY.

RELIABLE

These days, you're bound to be looking for better ways to squeeze more value out of every business asset — especially your trucks. A tough assignment if you operate in congested urban environments where length and weight restrictions can severely affect payload and profitability.

Introducing the all-new Kenworth K270 class 6 and K370 class 7, two of the most reliable, efficient and productive medium duty trucks ever to hit the boulevards and back alleys of urban North America. Add up the advantages — payload, productivity, reliability and uptime. Then consider one more thing: resale value. History proves that a used Kenworth is a better value to someone else than just about any other medium duty truck you can name.

MANEUVERABLE

Kenworth K270 and K370. Your uptown solution to doing business downtown.



The K270 and K370 cab offers a comfortable quiet, fully-trimmed interior with storage galore. Standard features include a multi-function steering wheel with adjustable steering column, power heated mirrors and windows, cruise control, Bluetooth capable audio and simple push-button drive for Allison 5 or 6-speed automatic transmissions.

WORKING IN THE CITY SHOULD BE A WALK IN THE PARK.

Another reason the K270 and K370 are destined to become urban leaders. For starters, entry and exit have been made safer, easier and less fatiguing. A spacious, quiet cab features the contemporary ergonomics and finish you'd expect to find only in fine automobiles. Gauges, switches and controls are easy to see and quick to reach. A high-tech master information module delivers real-time data at a glance. And shifting is push-button simple. Every detail thoughtfully engineered to keep the driver informed, in control and on schedule.



The dash has a familiar, contemporary design that presents critical driving information at a glance. An innovative 5 inch color master display module consolidates speed, engine RPM, oil level, fuel consumption, trip data, fault codes, outside air temperature, turbo pressure, PTO counter, service inspections and more. There is even an alarm clock.

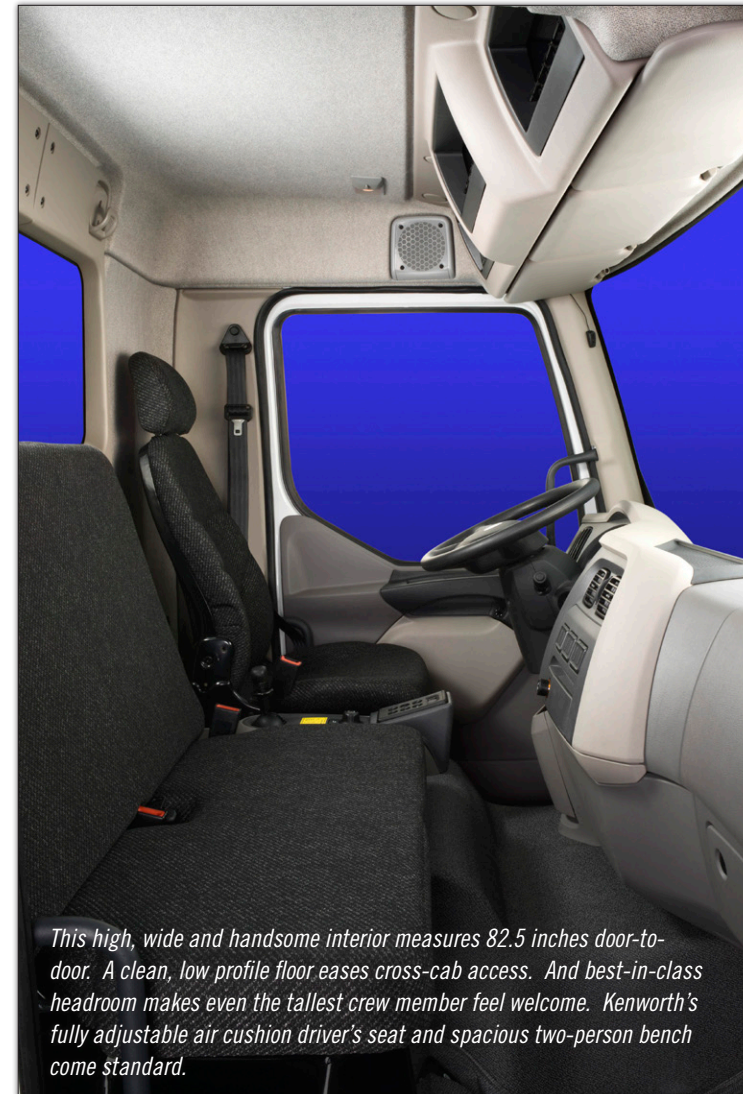

This high, wide and handsome interior measures 82.5 inches door-to-door. A clean, low profile floor eases cross-cab access. And best-in-class headroom makes even the tallest crew member feel welcome. Kenworth's fully adjustable air cushion driver's seat and spacious two-person bench come standard.

VERSATILE

PRODUCTIVE

EFFICIENT

RELIABLE

MANEUVERABLE

ADVANCED TECHNOLOGY, STREET-SMART DESIGN AND KENWORTH QUALITY.

Whether you run a major fleet or a three-person enterprise, the Kenworth K270 and K370 can put you back in control and miles ahead. Models include the K270 Class 6 and K370 Class 7, rated at 26,000 lbs and 33,000 lbs GVW respectively. Featuring a low chassis weight and 63.4 inch BBC dimension, these versatile vehicles are optimized for weight sensitive and high-volume payloads such as pickup and delivery, towing, refrigerated van, roll-off and landscape applications. The serviceability of the K270 and K370 was designed to save you money, with quick and easy access to all daily checks to keep you on the road.



The Kenworth K270 and K370 bring a sense of clarity, confidence and freedom to the act of driving. State-of-the-art practical technologies merge with world-class ergonomics to enhance safety, reduce fatigue and enable drivers of all experience levels to perform at peak efficiency.



A lockable compartment under the bench seat offers additional secure, out-of-sight storage for valuables, extra tools and equipment.



The optional single passenger seat configuration also offers a large locking center console that conveniently consolidates additional storage, cup holders, parking brake, control knob for master display functions, 12 volt power supply and the all-new push button shifting system for Allison automatic transmissions.



Kenworth's multi-function steering wheel puts the most frequently used controls — cruise control and engine brake — right under the driver's fingertips. The adjustable steering column telescopes in or out and tilts the wheel up or down for a personalized fit.



In just seconds — thanks to a hydraulic assist cab tilt of 55 degrees — your mechanic has complete and unfettered access to the engine, transmission, air filter and power steering reservoir.



With daily maintenance checks this easy, your K270 and K370 can clock into work right on schedule. Merely open the front access panel and — with feet firmly on the ground — you can check the levels and fill engine oil, coolant and washer fluid.



State-of-the-art complex reflector headlamps project a light beam farther and more evenly down the road, increasing the safety of night driving. Replacement bulbs are inexpensive and readily available at your local dealer or auto parts store. Fog lamps come standard for even greater forward visibility.



A short BBC dimension and a maximum 55-degree wheel cut combine to make the K270 and K370 nimble and quick even in tight spaces. 22.5 inch tires and wheels are standard, a perfect height for most loading docks. Wheels are offered in both steel and aluminum.

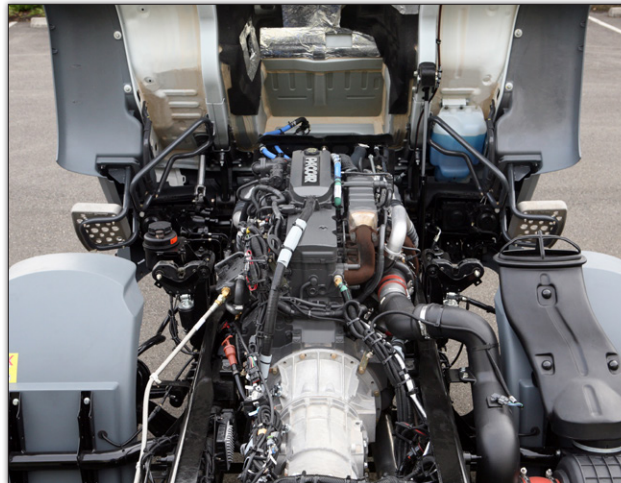

Standard equipment includes the proven, reliable and fuel efficient PACCAR PX-7 engine paired with an Allison 5 or 6-speed automatic transmission. You get plenty of power, acceleration and torque in a configuration that is a pleasure to drive.



The K270 and K370 has been designed to maximize your payload potential. Starting at only 10,000 pounds, this light weight yet extremely durable chassis features proven North American-supplied components assembled with the meticulous care and craftsmanship that marks Kenworth quality. Constructed of 120,000 PSI-rated steel, the frame provides a 34-inch rail spacing.



KENWORTH K270 AND K370 DIMENSIONS

Standard Chassis Configuration

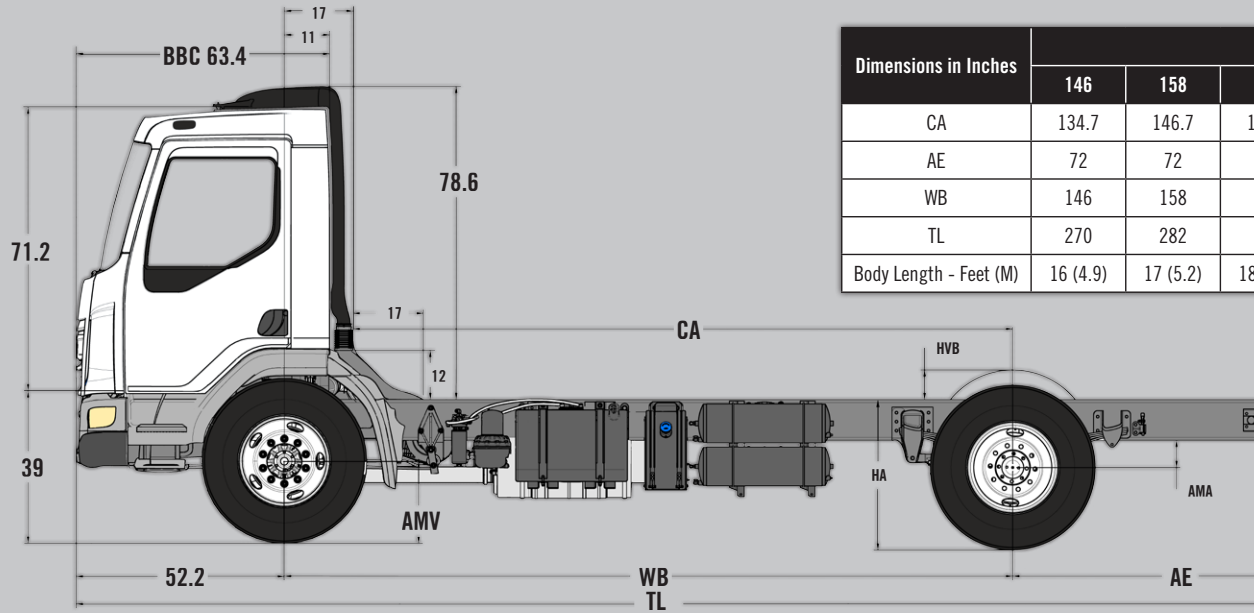

Dimensions in Inches	Standard Chassis Wheelbases								
	146	158	170	182	194	206	218	230	242
CA	134.7	146.7	158.7	170.7	182.7	194.7	206.7	218.7	230.7
AE	72	72	72	84	96	108	120	120	120
WB	146	158	170	182	194	206	218	230	242
TL	270	282	294	318	342	366	390	402	414
Body Length - Feet (M)	16 (4.9)	17 (5.2)	18 (5.5)	20 (6.1)	22 (6.7)	24 (7.3)	26 (7.9)	27 (8.2)	28 (8.5)

Dimension in Inches	Spring Suspension		Air Suspension	
	Unladen	Laden	Unladen	Laden
AMA	9.0	7.5	8.5	8.3
AMV	20.0	18.5	20.0	18.5
HA	39.5	37.0	38.5	36.0
HBV	—	1.5	—	0.2

Clear Frame Rail Chassis Package Configuration

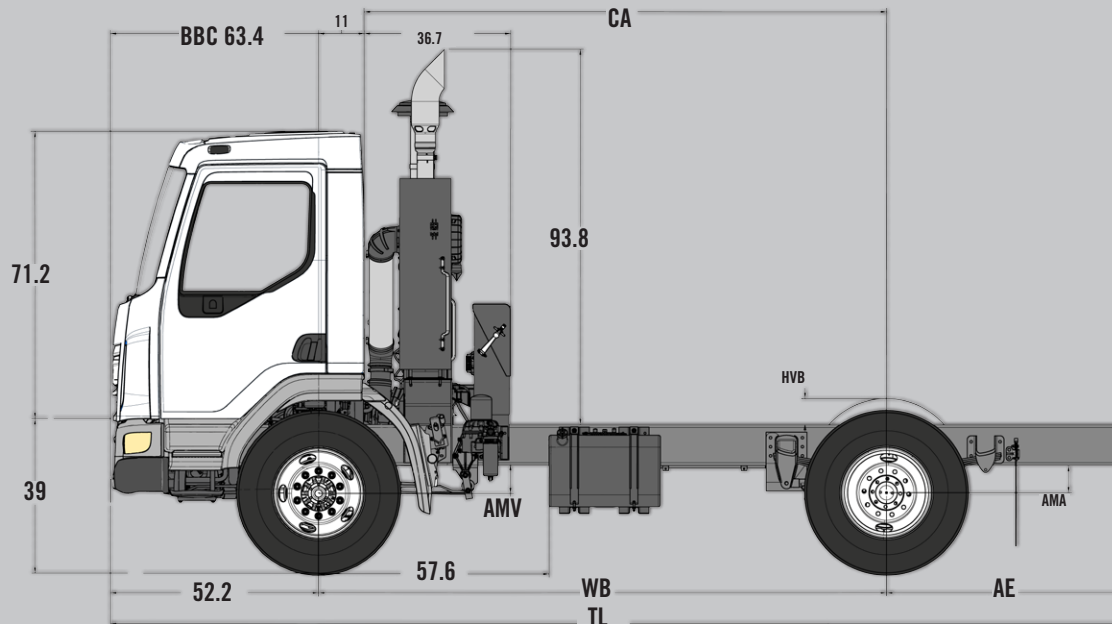

Dimensions in Inches	Clear Rail Chassis Wheelbases		
	142	146	158
CA	130.7	134.7	146.7
AE	72	72	72
WB	142	146	158
TL	266	270	282
Body Length - Feet (M)	13 (3.8)	16 (4.9)	17 (5.2)

Dimension in Inches	Spring Suspension		Air Suspension	
	Unladen	Laden	Unladen	Laden
AMA	9.0	7.5	8.5	8.3
AMV	20.0	18.5	20.0	18.5
HA	39.5	37.0	38.5	36.0
HBV	—	1.5	—	0.2

KENWORTH K270 AND K370 MEDIUM DUTY CABOVER SPECIFICATIONS

PACCAR Engine

- PACCAR PX-7 6-Cylinder, 6.7 L, EPA 2013
- 220HP@2400, 520@1600
- 240HP@2400, 560@1600
- 250HP@2400, 660@1600

Engine Equipment

- Alternator - 160 Amp
- K270 Transmission - Allison 5-Speed 2100 HS
- K370 Transmission - Allison 5-Speed 2500 HS
- Allison 3000HS 5 Speed Transmission
- Allison RDS Series Transmission
- Allison 6 Speed Transmissions
- Fuel Tank - 45 Gallon, Rectangular
- Dual 45 Gallon Rectangular Fuel Tanks
- DEF Tank - 7.5 Gallon, Rectangular
- Exhaust - Horizontal Crossover DPF/SCR w/Horizontal Tailpipe
- Two PACCAR 700 CCA Batteries
- Two PACCAR 1000 CCA Batteries

Gross Axle Weight Rating

- | | |
|-------------------|-----------------------|
| • K270 Front | 10,000 lbs. |
| • K370 Front | 12,000 lbs. |
| • K270 Rear | 16,000 lbs. |
| • K370 Rear | 21,000 lbs. |
| • Rear Axle Ratio | 5.29 or 5.57 |
| • Rear Axle Ratio | 4.63 with 19.5" Tires |

Suspensions

- Front Suspension - Parabolic Spring
- Rear Suspension - Reyco Mechanical
- Rear Suspension - Hendrickson HAS210 or HAS230 Air Ride

Wheels / Tires / Brakes

- Wheels - 22.5" Steel Painted White
- Wheels - 19.5" Steel Painted White
- Aluminum Wheels
- Tires - F/R: Bridgestone 11R22.5"
- Tires - F/R: Bridgestone 19.5"
- Brakes - Front and Rear Drum
- Front Air Disc

Frame

- 33.9" Frame Spacing
- Steel Painted Gray Bumper
- Section Properties Per Rail:
Frame Section Modulus RBM 11.65 Cu In, 1,398,664 lb/in

Electrical System

- 12 Volt Starting and Charging System
- Exterior Lighting 12 Volt
- Two 12-Volt Power Ports in Cab
- Body Builder Connections 12 Volt

Cab

- Hydraulic 55 Degree Tilting Steel Cab
- K270/K370 78.6" Top of Frame Rail to Top of Cab - 22.5" Tires
- K270/K370 52.2" Bumper to Center of Front Axle - 22.5" Tires
- 82.5" Cab Width
- Driver Seat - Air Suspension
- Passenger Seat - 2-Person Bench
- Passenger Seat - Single Person Air Ride
- Center Storage Console and Cupholders
- Heater and Air Conditioning
- Cruise Control
- Power Windows
- Power Mirrors
- Heated Mirrors

- Doors Open 90 Degrees
- Cab Suspension - Maintenance-Free
- Dash Displays - English
- Outside Air Temperature Display
- Coolant Temperature Display
- Dual Air Pressure Gauges
- AM/FM/WB/USB, Bluetooth Radio
- AM/FM/CD/WB/USB, Bluetooth Radio
- Roof Mounted Air Intake Snorkel

Paint

- Cab - Ice White Axalta N8870
- Frame - Black

Options

- Switch and Wiring for Customer Installed PTO
- Wiring only for Customer Installed Backup Alarm
- Speakers and Wiring for Customer Installed Radio
- Oil Pan Heater 300 Watt
- Immersion Pre-Heater 120 Volt
- Heated Fuel Filter
- Rear Shock Absorbers - Reyco
- Rear Axle Stabilizer Bar - Reyco
- Rear Differential Lock
- Rear Mud Flap Hanger & Shields
- Backup Alarm
- Orange Seat Belts
- Red Seat Belts
- Clear Frame Rail Package BOC, Inboard Mounted
 - Vertical Exhaust/Air Filter
 - DEF Tank
 - Battery Box
 - Air Tanks
 - 6.50 or 7.17 Rear Axle Ratio



KENWORTH
THE WORLD'S BEST.

K270/K370



PACCAR PX-7

The K270 and K370 come standard with the PACCAR PX-7 engine rated up to 250 hp and 660 lb-ft of torque. A proven workhorse, the PACCAR PX-7 produces the highest horsepower to weight ratio of any engine in the industry. The right choice for demanding applications, the PACCAR PX-7 offers extended service intervals, advanced fuel efficiency and reliability you'll measure in peace of mind.

VERSATILE

Specifications

CONFIGURATION	INLINE 6-CYLINDER
DISPLACEMENT	6.7 LITERS
DRY WEIGHT	1,151 LBS.
OIL SYSTEM CAPACITY	18 U.S. QUARTS
HORSEPOWER	220-250 HP
PEAK TORQUE	520-660 LB.-FT.
GOVERNED SPEED	2,600-2,800 RPM
CLUTCH ENGAGEMENT TORQUE [†]	400 LB.-FT. @ 700 RPM

[†]Determined By Engine Horsepower And Idle Setting
[‡]Extended Protection Plans Available

Ratings

ENGINE HORSEPOWER	PEAK TORQUE LB-FT @ RPM	GOVERNED RPM
220	520 @ 1,600	2,600
240	560 @ 1,600	2,600
250	660 @ 1,600	2,600

Maintenance Intervals

MAINTENANCE ITEM	MILES	KILOMETERS
FUEL FILTER	15,000	24,000
OIL AND FILTER	15,000	24,000
DEF FILTER	200,000	320,000

Note: Equipment and specifications shown in this brochure are subject to change without notice. Consult with your PACCAR Engine dealer at time of ordering for standard and optional equipment. PX-7 is a trademark of PACCAR Inc

Horsepower

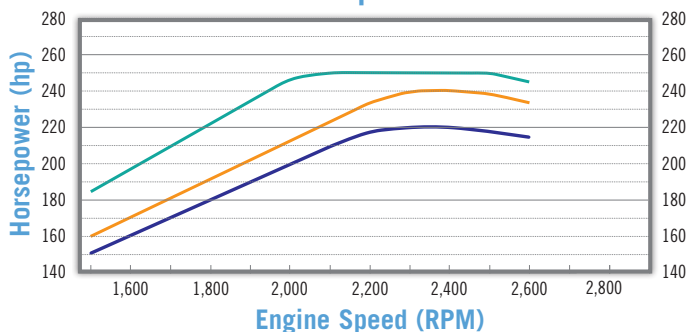

PRODUCTIVE

Torque

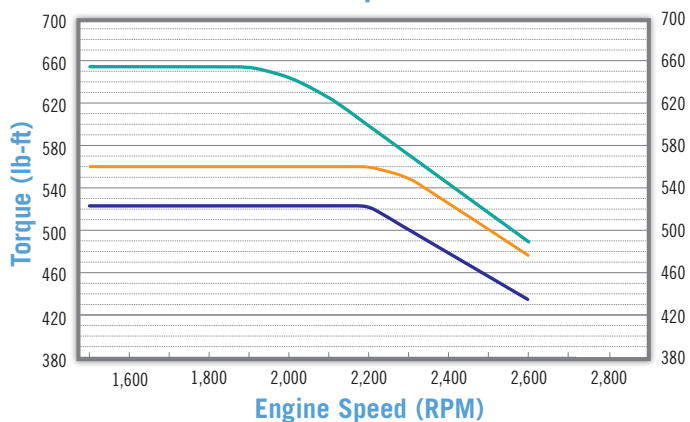

EFFICIENT

RELIABLE

MANEUVERABLE

Horsepower (kW)	220 (164)	240 (179)	250 (186)
	■	■	■

SUPPORT WHENEVER – AND WHEREVER – YOU NEED IT

The reliability and moneymaking potential of your business relies on the dependability of your support system – another great reason to invest in a Kenworth.

The minute you take delivery of your Kenworth, you gain 24/7 access to one of the most extensive and reliable parts and service organizations in the trucking industry. People who know your truck inside out and can show you how to lower operating expenses, maximize uptime, optimize truck performance and profit from your investment. Comprehensive preventive maintenance programs, expedited servicing, complimentary roadside assistance and cost management service cards are among the valuable programs available through Kenworth PremierCare®.



Perhaps you'd prefer to focus your attention and resources on your core business, save interest expense and improve cash flow. PacLease offers a number of truck rental and leasing programs that can be tailored to fit your operating requirements precisely. www.paclease.com

Start with a lender who understands your business. PACCAR Financial has served owner-operators and fleets for over 40 years, matching individual requirements with customized financing packages at attractive and competitive rates. Financing and insuring your new truck has never been this easy. www.paccarfinancial.com



Note: Photography and illustrations in this brochure may depict optional equipment. All equipment and specifications shown in this brochure are subject to change without notice. Please consult with your Kenworth dealer at the time of ordering for actual standard and optional equipment. PX-7 is a registered trademark of PACCAR Inc



Follow us on:



A **PACCAR** COMPANY

KENWORTH TRUCK COMPANY

P.O. Box 1000

Kirkland, Washington 98083-1000

(425) 828-5000

CANADIAN KENWORTH COMPANY

6711 Mississauga Road, Suite 500

Mississauga, Ontario L5N 4J8

(905) 858-7000

www.kenworth.com

